



ISCA-131-D

Tag: _____

Industry Standard Back-To-Back Vertical Adj. Closet Carrier w/Side Inlet

SPECIFICATION: Watts Drainage Products ISCA-131-D *Industry Standard* back-to-back vertical adjustable water closet carrier with epoxy coated cast iron fitting, 4"(102) no hub waste and 2"(51) no hub vent connections, 4"(102) no hub side inlet(s), epoxy coated cast iron patent pending compression seal faceplate assembly, epoxy coated cast iron foot supports adjustable for standard and wheelchair height, adjustable ABS nipple with integral test cap and neoprene bowl gasket, plated hardware and chrome cap nuts.

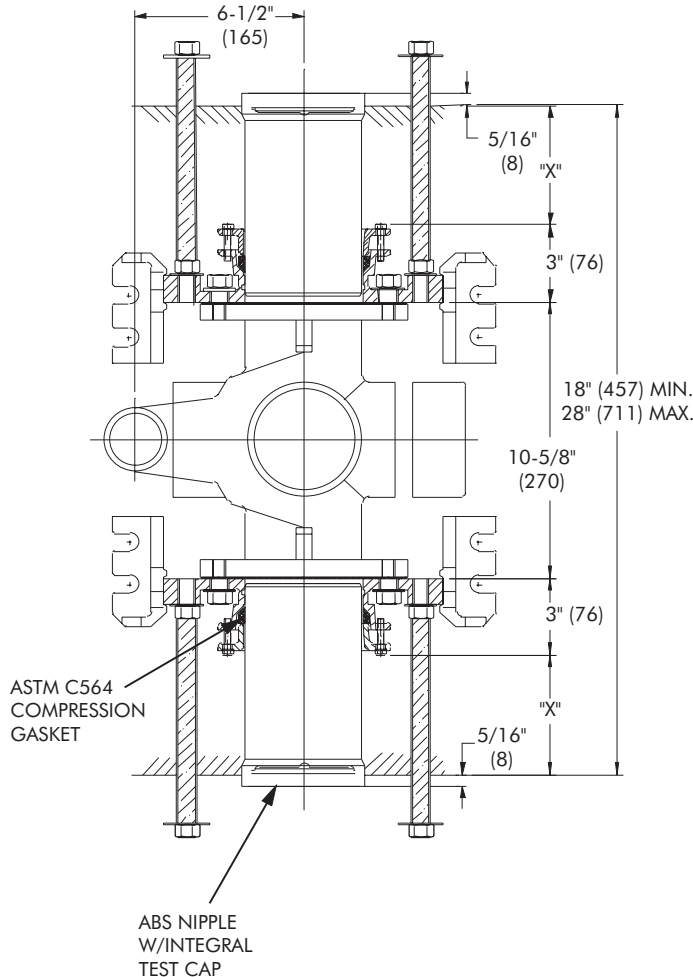

Options (Select One or More)		
Suffix	Description	
CA-100-EXT	Aux. Support System w/Extended Nipple	<input type="checkbox"/>
-M1	ABS Extended Nipple (Up to 24")	<input type="checkbox"/>
-M11	Tiling Frame	<input type="checkbox"/>
-M20	Flush Valve Support	<input type="checkbox"/>

Notes:
Siphon jet (4 bolt) arrangement shown. Invert faceplate assembly for blow-out (3 bolt) bowls.

Anchor legs to concrete floor with minimum 1/2" lag bolts (by others).

X = 5-3/4" (146) Maximum with Standard Nipple

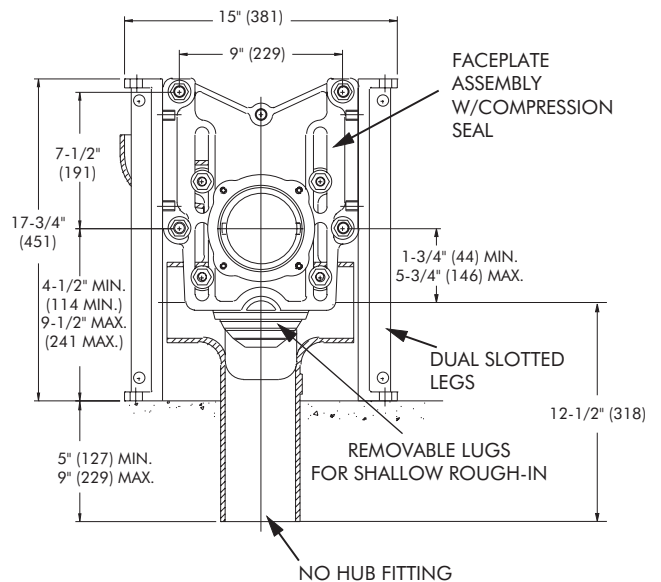

Job Name _____ Contractor _____

Job Location _____ Contractor's P.O. No. _____

Engineer _____ Representative _____

Watts Drainage reserves the right to modify or change product design or construction without prior notice and without incurring any obligation to make similar changes and modifications to products previously or subsequently sold. See your Watts Drainage representative for any clarification. Dimensions are subject to manufacturing tolerances.



USA: 100 Watts Road, Spindale, NC, 28160 TEL: 828-288-2179 TOLL-FREE: 1-800-338-2581 Website: www.wattsdrainage.com